



HPTEC

526
516

***Vollhartmetall-
Spiralbohrer zum
Bohren von
Leiterplatten***

***Solid carbide
drills for drilling
of printed
circuit boards***

***Forets en carbure
monoblocs pour
le perçage des
circuits imprimés***

Vollhartmetall-Microbohrer, rechtsschneidend, Typ 516 mit Schaft- \varnothing 3.175 mm (1/8"), 2-stufig abgesetzt. Vollhartmetall-Spiralbohrer, rechtsschneidend, Typ 526 mit Schaft- \varnothing 3.175 mm (1/8").

Solid carbide micro-drills, right hand cut, Type 516 with shank-dia. 3.175 mm (1/8") 2-stepped down. Solid carbide drills, right hand cut, Type 526 with shank-dia. 3.175 mm (1/8").

Micro-forets en carbure monoblocs, coupe à droite, Type 516 diamètre de queue 3.175 mm (1/8"). Forets en carbure monoblocs coupe à droite, Type 526 diamètre de queue 3.175 mm (1/8").

*auf Anfrage
* on request
*sur demande

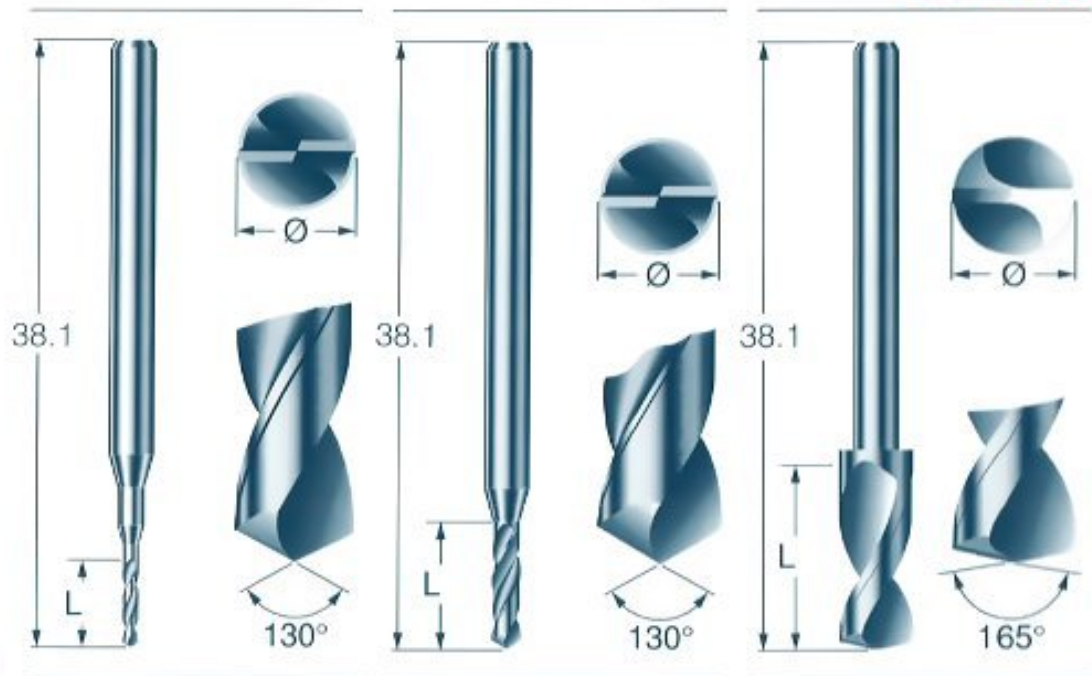

516

\varnothing mm	L mm
0.1 *	1.5
0.15*	2.0
0.2	3.5
0.2 *	5.0
0.25	3.5
0.25*	5.0
0.3	5.5
0.3	7.0
0.35	5.5
0.35	7.0
0.4	5.5
0.4	7.0
0.4	8.5
0.45	5.5
0.45	7.0
0.45	8.5
0.5	5.5
0.5	7.0
0.5	8.5

526

\varnothing mm	L mm
0.55	7.0
0.55	8.5
0.6	7.0
0.6	8.5
0.65	7.0
0.65	8.5
0.70	10.5
0.75	10.5
0.8	10.5
.	.
.	.
3.15	10.5
3.175	10.5
3.20	12
3.25	12
3.30	12
.	.
.	.
7.00	12