

PCB Separators PCB Magazines Minilifts

Precision - Made in Germany



Behind every development and construction from the company cab is not only long standing know-how but also captive philosophy:
Do not concentrate on a single piece of equipment: think in complete systems.

Systems which interlock, complement each other and thus come up to the constantly growing demands and terms of the electronic industry.

PCB Separators – cab Produkttechnik is worldwide no. 1 -, the PCB Magazines and cablift, the *Minilift*, result in a perfect team which contributes significantly to the following: to shorten, simplify and improve the production and workflow process in your company with intelligent assistants.

Made in Germany with a large vertical range of manufacture our quality system is subject to DIN ISO 9001 - from receiving inspection up to consignment.

The current specifications are according to our technical knowledge. They are subject to change.

**Off-cut Remover
HEKTOR 2**



3

**PCB Separator
MAESTRO 2/2M**



4

**PCB Separator
MAESTRO 3E**



5

**PCB Separator
MAESTRO 4M**



6 - 7

**PCB Separator
MAESTRO 5L**



8 - 9

**Dust extractor
Industry dust
extractor**



10

Minilift



11

**PCB
Magazines
Series 100 / 180 / 300**



12 - 15

**PCB
Magazines
Series 600 / 700**



16 - 19



Hektor separates milled PCBs carefully and fast. The off-cut material is removed smoothly and precisely. The matrix consists of two parts. This ensures easy and cost-saving change of the blades. Compressed air is used for the separation process. The operating pressure can be set on the machine. When the foot switch is pressed, the off-cut is punched out. The off-cuts are collected in the collecting box. When the gate is opened the waste material can be extracted.

Safe Operation

The PCB is slipped with its milled groove over the blade and is placed onto the matrix. The off-cut is pulled under the blade. When the foot switch is pressed, the off-cut is punched out and the waste material is collected inside the machine.

Part No.	Description
8932145	Off-Cut Remover Hektor 2 Contents of delivery: Hektor 2 with air pressure regulator Foot switch Adapter for dust extraction 1 L-blade – Please choose the size

Technical Data	
Separation type	Punch blade
PCB thickness	max. 2.5 mm
Air connection	1/4"-plug-in coupler
Operating pressure	typical 4 bar
Mains voltage	10 - 35° C
Storage/transport temperature	-20 - 50° C
Humidity, non-condensing	10 - 85%
Safety regulations	CE, FCC class 1
Weight	2.7 kg
Dimensions H x W x D	170 x 220 x 255 mm



T-Blade

With the T-blade off-cuts can be punched out right and left of the blade without turning the PCB.



L-Blade

The L-blade will be used if there are small distances between the off-cuts.

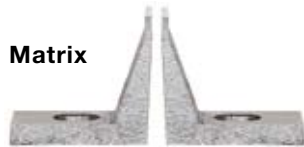

Matrix

Included in delivery.

Blades

To ensure the blade will not be jammed in the PCB, the blade should be at least 0,15 mm smaller as the milled groove.

Part No.		A	B	C	D	E	F	G	
8932137	Blade 1,5 T	≥1,5	1,35	17,2	4,7	>19,0	>19,0	3,0	
8932138	Blade 2,0 T	≥2,0	1,85	17,2	5,2	>19,0	>19,0	3,0	
8932191	Blade 2,4 T	≥2,4	2,25	18,0	5,7	>19,0	>19,0	3,0	
8932139	Blade 2,5 T	≥2,5	2,35	18,0	5,7	>19,0	>19,0	3,0	
8932144	Blade 3,0 T	≥3,0	2,85	18,0	5,7	>19,0	>19,0	2,5	
8932122	Blade 1,5 L	≥1,5	1,35	12,0	4,7	>15,0	>13,0	3,0	
8932123	Blade 2,0 L	≥2,0	1,85	12,0	5,2	>15,0	>13,0	3,0	
8932141	Blade 2,4 L	≥2,4	2,25	12,0	5,7	>15,0	>13,0	3,0	
8932124	Blade 2,5 L	≥2,5	2,35	12,0	5,7	>15,0	>13,0	3,0	
8932125	Blade 3,0 L	≥3,0	2,85	12,0	5,7	>15,0	>13,0	2,5	
8932171	Matrix (as spare part)								

Blades with varying thickness on request.

4 PCB Separator MAESTRO 2/2M



MAESTRO 2 separates small amount and prototype series of PCBs fast and economically. The compact and stable aluminum frame requires only a minimum of space.

MAESTRO 2

is the reasonable model to start with, suitable for smaller numbers of PCBs. The PCB is fed manually between the circular blades and is thereby separated.

MAESTRO 2M motorized

Separates large numbers of PCBs without fatigue of the operator. The lower circular blade is driven by a motor. The PCB is fed between the circular blades where it is seized, transported and separated. Three different speeds can be selected.

Strain of components

Frequently for critical components an upper limit of tensile stress will be determined. Please ask us regarding possibilities to reduce tensile stress of components.

Save Operation

The PCB is held with both hands and fed between the circular blades for separation. The clearance between the upper guide **1** and the lower guide **2** is adjustable to ensure that the PCB is only fed through the machine in the pre-scored groove.



Maximum height of components next to the groove

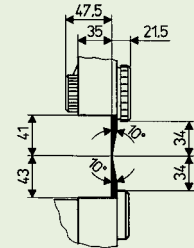

PCB thickness A	0.8 - 3.2 mm
Remaining PCB thickness B	typical 1/3 of Dim. A max. 0.8 mm
Depth of scoring C	min. 0.25 mm
Increase in external dimensions after separation	0.1 - 0.2 mm

The pre-scored grooves can be interrupted by cutouts with a length of up to approx. 5 mm.

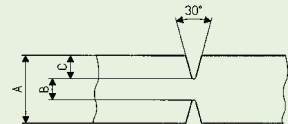

Technical Data

Separation type	Component side circular blade Solder side circular blade
Operation	MAESTRO 2 by hand MAESTRO 2M motor-driven
Separation speed 2M	100/200/300 mm/s
Separation length	15 - 300 mm
Mains voltage 2M	230/115 V ~ 50 - 60 Hz
Earthing stud	Ø 10 mm
Operating temperature	10 - 35° C
Storage/transport temp.	-20 - 50° C
Humidity non-condensing	10 - 85%
Safety regulations	CE, FCC class 1
Weight	MAESTRO 2 16 kg MAESTRO 2M 19 kg
Dim. H x W x D	330 x 195 x 620 mm

Part No.

Description

8933900	PCB Separator MAESTRO 2
8933935	PCB Separator MAESTRO 2M

Pos.	Part No.	Spare parts	PU
1	8930509	Upper circular blade	1
2	8930744	Upper guide	1
3	8933661	Lower circular blade	1
4	8930745	Lower guide	1



MAESTRO 3E separates both small and large pre-scored PCBs. The table and the rest can be continuously adjusted to the most suitable working position. The slit between the linear blade and the rest can be adjusted to ensure that the side strips fall through and are sorted out.

Strain of components

Frequently for critical components an upper limit of tensile stress will be determined. Please ask us regarding possibilities to reduce tensile stress of components.

Safe Operation

The PCB is placed with its pre-scored groove onto the linear blade and the circular blade is then drawn by hand across the PCB. The clearance between the upper guide and the linear blade is adjustable to ensure that the PCB is only separated in the pre-scored groove.



Maximum height of components next to the groove.

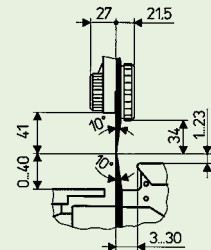

If components project above the groove, the linear blade needs to be cut out. In such a case contact us.

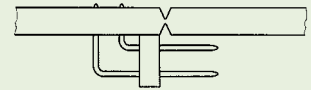

PCB thickness A	0.8 - 3.2 mm
Remaining PCB thickness B	typical 1/3 of Dim. A, max. 0.8 mm
Depth of scoring C	min. 0.25 mm
Increase in external dimensions after separation	0.1 - 0.2 mm
The pre-scored grooves can be interrupted by cutouts with a length of up to approx. 5 mm.	

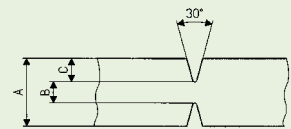

Technical Data	
Separation type	Component side circular blade Solder side linear blade
Operation	by hand
Separation length	max. 450 mm
Earthing stud	Ø 10 mm
Operating temperature	10 - 35° C
Storage/transport temp.	-20 - 50° C
Humidity, non-condensing	10 - 85%
Safety regulations	CE, FCC class 1
Weight	22 kg
Dim H x W x D	455 x 350 x 700 mm

Part No.	Description		
8933945	PCB Separator MAESTRO 3E/450		
Pos.	Part No.	Spare parts	PU
1	8930509	Upper circular blade	1
2	8930603	Guide 2 up to serial no. 1999	1
2	8936615	Guide 2 from serial no. 2000	1
3	8930602	Guide 1 up to serial no. 1999	1
3	8936614	Guide 1 from serial no. 2000	1
4	8933394	Linear blade 450/370	1

6 PCB Separator MAESTRO 4M



MAESTRO 4M separates both small and large PCBs fast and economically. To optimize operation, the separation length can be programmed with the control keys.

Strain of components

Frequently for critical components an upper limit of tensile stress will be determined. Please ask us regarding possibilities to reduce tensile stress of components.

Safe Operation

The PCB is placed with its pre-scored groove onto the linear blade. When the foot switch is pressed, the blade carrier with the circular blade moves across the PCB, separating it into individual units.

The clearance between the upper guide and the linear blade is adjustable to ensure that the PCB is only separated in the pre-scored groove. The table can be continuously adjusted with the rotary knob whenever required while the rest can be adjusted in three steps to the most suitable working position.

Foto:
MAESTRO 4M clean
with dust extraction
and conveyor belt



If components project above the groove, the linear blade needs to be cut out. In such a case, contact us.

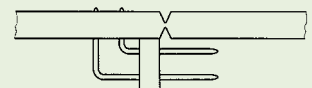

PCB thickness A	0.8 - 3.2 mm
Remaining PCB thickness B	typical 1/3 of Dim. A, max. 0.8 mm
Depth of scoring C	min. 0.25 mm
Increase in external dimensions after separation	0.1 - 0.2 mm

The pre-scored grooves can be interrupted by cutouts with a length of up to approx. 5 mm.

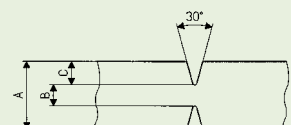



MAESTRO 4M/450
MAESTRO 4M/450 clean

Component height at the edge on the PCB max. 40 mm



Dust Extraction

The extraction volume can be adjusted on the machine.
More information: see page 10.

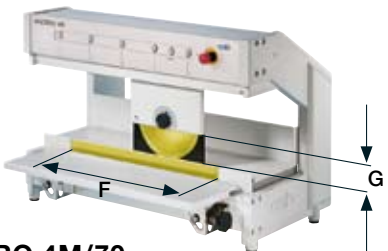

MAESTRO 4M/70

Component height at the edge on the PCB max. 70 mm

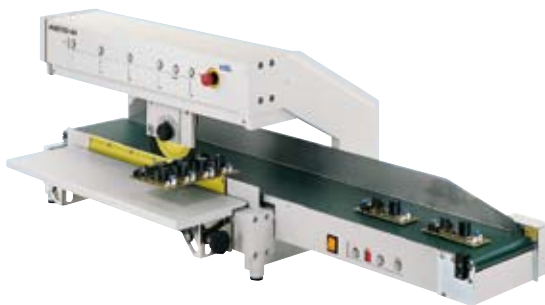

Conveyor belt for higher performance

The PCBs are transported out of the machine after separation. The light barrier at the end of the conveyor belt can stop the arriving PCBs.

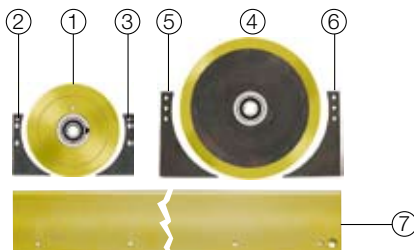

Technical Data PCB Separator

Separation type	Component side circular blade Solder side linear blade
Operation	Optimized motor driven
Separation speed	300/500 mm/s
Mains voltage	230/115 V~ 50 - 60 Hz
Earthing stud	Ø 10 mm
Operating temperature	10 - 35° C
Storage/transport temp.	-20 - 50° C
Humidity, non-condensing	10 - 85%
Safety regulations	CE, FCC class 1

Technical Data Conveyor Belt

Material of conveyor belt	Antistatic
Direction of belt travel	To the right
Belt speed	5/6/7/8/9 m/min
Light barrier	Can be activated for belt stoppage
Safety regulations	CE, FCC class 1
Width of table	540 mm
Weight	14 kg

Maximum height of components next to the groove

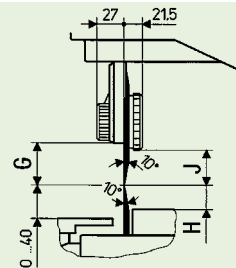

H

Table 9 - 39

Conveyor belt 5 - 17

Part No.	Descriptions	Length of device	Height of device	Separation length	Component height before the groove	Component height behind the groove	Weight in kg
8933955	PCB Separator MAESTRO 4M/450	702	434	450	40	34	38
8933950	PCB Separator MAESTRO 4M/450 clean	702	434	450	40	34	39
8933965	PCB Separator MAESTRO 4M/70	702	492	370	70	64	40
8931240	Conveyor belt						

Pos.	Part No.	Spare parts	PU
1	8930509	Upper circular blade	1
2	8930603	Guide 2 up to serial no. 1999	1
2	8936615	Guide 2 from serial no. 2000	1
3	8930602	Guide 1 up to serial no. 1999	1
3	8936614	Guide 1 from serial no. 2000	1
4	8933939	Circular blade passage height 70 mm	1
5	8930756	Guide 2/70	1
6	8930755	Guide 1/70	1
7	8933394	Linear blade 450/370	1
7	8933931	Linear blade 450/370 clean	1

8 PCB Separator MAESTRO 5L



Strain of components

Frequently for critical components an upper limit of tensile stress will be determined. Please ask us regarding possibilities to reduce tensile stress of components.

MAESTRO 5L

is used most economically whenever large numbers of pre-scored PCBs need to be separated. The well-arranged control panel ensures easy operation. PCB panels with a maximum width of 310 mm can be separated by up to 10 circular blades simultaneously. Sensors are used to monitor the separation process. The PCBs are placed either by hand or they are fed automatically by a loading station. The machine can also be installed in an assembly line. The SMEMA interface is the standard connection for this use. The PCB Separator MAESTRO 5L can be adjusted to your PCB and your individual requirements. For PCB panel widths larger than 310 mm on request.

PCB thickness A	1.0 - 3.2 mm
Remaining PCB thickness B	typical 1/3 of Dim. A min. 0.3 mm, max. 0.6 mm
Depth of scoring C	min. 0.3 mm
Increase in external dimensions after separation	0.1 - 0.2 mm
The pre-scored grooves can be interrupted by cutouts with a length of up to approx. 5 mm.	



The machine is supplied with a heightadjustable base. In this way it can be adapted optimally to every requirement.



MAESTRO 5L Customer-specific application

The separated PCBs are transported by the conveyor belt for further treatment. Workplaces are arranged on the right and on the left of the belt. The side strips drop down into a collecting box.



Dust Extraction

The Dust Extractor can be switched on directly on the PCB Separator. More information: see page 10.



Technical Data	
Separation type	Component side circular blade Solder side circular blade
Operation	motorized
Separation speed	100 - 220 mm/s in 10 steps
Length of PCB panel with light barrier activated with light barrier de-activated	100 - 570 mm > 100 mm
Width of PCB panels	max. 300 mm
Width off-cut	min. 3 mm
Height of components	Component max. 30 mm Solder side max. 10 mm
Number of circular blades	max. 10
Width of PCBs	10 - 290 mm
Display	- Separation speed - Separated lenght or numbers of PCB panels
Keys	- Start, stop, reverse - Setting of separated speed
Monitoring	- Detection of separation lenght - Accumulation in front of and behind the blades - Stop the end of the
Interfaces	- conveyor belt - Remote start/stop - SMEMA (round 14 pins)
Mains voltage	230 /115 V~ 50 - 60 Hz
Operating temperature	10 - 35° C
Storage/transport temp.	-20 - 50° C
Humidity non-condensing	10 - 85%
Weight	63 kg
Dimensions with base height width dept	750 - 1000 mm 440 mm 1100 mm

Part No.	Description	
8934520	PCB Separator MAESTRO 5L Contents of delivery: MAESTRO 5L with base Circular blades on customer request Service tools	
Part No.	Spare parts	PU
8934803	Circular blade width 8 mm	1

10 Industry dust extractor

for PCB Separators 4M/5L



Harmful dusts occur when separating PCB's by scoring, sawing, stamping and milling. These dusts can be removed with the Dust Extractor according to regulations. When using the Dust Extractor with the PCB the extractor is switched on together with the machine. The extraction volume is adjustable on the machine.



The Industry dust extractor is supplied regularly with a BIA* K1 filter. Glasfibre reinforced plastics and other hazardous materials will be extracted according to EC health regulations.

Accessories

In the cover of the device you find three additional nozzels. The working place and the device can be cleaned quick and easily.

Technical Data

Power	P max./IEC	1250/1100 W
Amount of air		3120 L/min.
Transmission factor		0.05%.
Capacity		14 L
Sound pressure level		61 dB
automatic filter control		no
Length of vacuumer tube		2,5 m
Length of power cable		12 m
Power supply		230 V~ 50 - 60 Hz
Safety regulations		CE, FCC class 1
Weight		9 kg
Dimensions H x W x D		350 x 400 x 550 mm

Part No.

Description



8932620

Industry dust extractor
Contents of delivery:
1 Industry dust extractor
10 Paper filter bags BIA U,S,G,C
1 Micro filter BIA K1
3 additional nozzels

Part No.

Spare parts

PU



5905493

Paper filter bags BIA U,S,G,C 10



8932911

Micro filter BIA K1 1

The cablift for lifting, lowering, turning and pivoting



The Minilift as a flexible magazine-loader

With 20 standard and more than 100 special versions we offer you the optimal solution.



The Minilift at the working environment

Please find more information in our cablift-catalogue or on www.cabgmbh.com.

Abridged version of the delivery programme

Platform with load auxiliary rolls



They allow an easy loading and unloading lengthwise and lateral direction.

Container platform



For retaining of norm containers 600 x 400. The height is variable.

Turn table



The magazine can be reversed after loading at 90° or 180°.

Rotating modulus



For PCB-magazines which have to be reversed at 180° for further processing.

There is a system behind it



The cab PCB magazines can be filled when standing vertical or laying horizontal. The system is totally adjustable for width and can be assembled according to your individual requirements. For different size PCBs we offer PCB magazines with a height of 100, 180 and 300 mm.

All magazines have 32 slots, each with a 10 mm clearance between them, thereby providing maximum use of available space.

Secure

The precision molded slots are funnel shaped at each end to simplify the insertion of each circuit board. The location of each mounting slot is shown by yellow and white positioning strips. These enable boards to be loaded while avoiding the risk of being loaded by hand in the wrong position.

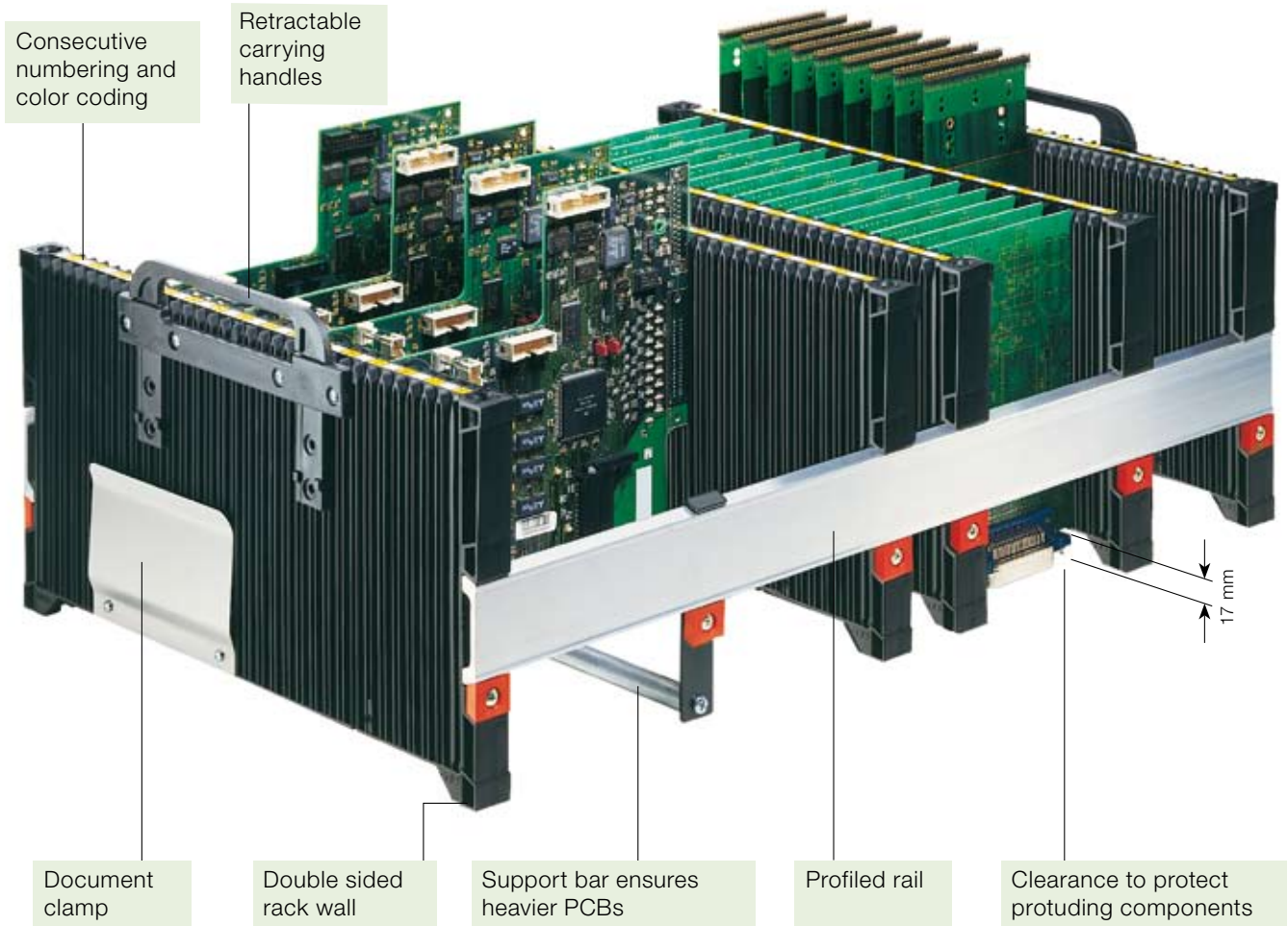



Fast and easy assembly

The magazine walls can be secured to the profiled rails in any position required. Two identically sized circuit boards are inserted between the walls, into the adjustment slots at the extreme ends of each wall. The second wall is then pressed firmly onto the boards and screwed tight.

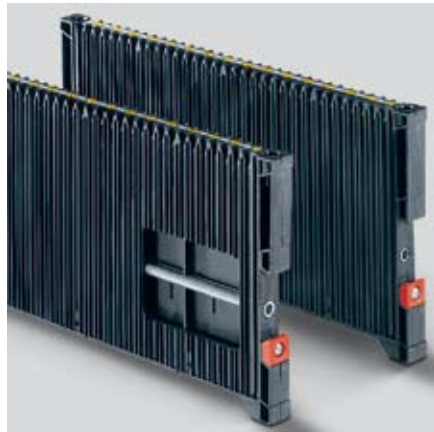

Rigid and stable

The magazine walls are constructed in sandwich form, and are therefore particularly rigid. For heavy mechanical and thermal force the magazine walls can additionally be reinforced by the use of a steel rod.



Slot lock

To prevent damage to the PCB board during insertion, we offer slot locks which cover slots not in use.



Stackable

At the corners of each magazine are male and female connectors which allow the racks to be stacked upon another. The lower edge of each magazine-side has a molded recess which allows the magazine to be gripped and lifted without problem.



Vertical mounting

Before soldering, the circuit board must be stored horizontally. The magazine can therefore stand vertically.



Transport containers

For transport purposes, the PCB magazines can be loaded into containers. These containers have norm sizes of 600 x 400 mm and 400 x 300 mm. Retractable handles enable the magazines to be removed with ease.

14 PCB Magazines Series 100 / 180 / 300

with 32 slots

Flexing of the magazine walls under loading

When the PCB Magazine is correctly assembled, each side wall may flex less than 1,0 mm, to ensure a secure mounting of the PCB. The measurements were using 16 circuit boards, with a clearance of 20 mm between each other, and a weight per board of 500 g. Upon request, a copy of the test report is available.

Critical loading can occur as follows:

1. When the magazine is laid on its side on a flat surface, and then lifted.
2. When being transported in the vertical position, and the position is changed to the horizontal.

Technical Data	100	180	300
Material	Polypropylene		
Color	black		
Surface resistance	as per DIN EN 61340-5-1 < 10 ⁹		
Dimensions			
Slot width mm	2.8	4.0	3.5
Slot depth mm	2.0	2.5	2.5
Ammount	32	32	32
Distance of PCBs mm	10	10	10
Flexing with a total load of 8 kg			
Temperature 23°C not reinforced	1.0	0.8	0.4
Temperature 23°C with reinforced	0.5	0.4	-
Temperature 70°C not reinforced	-	-	0.8
Temperature 70°C with reinforced	0.9	0.7	-

The length of profiled rail (Dimension X) is calculated based upon the dimensions as shown below.

Dimension D = PCB Width
Dimension X = Length of Profiled Rail

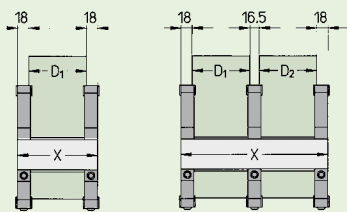

$$x = 36 + D1$$

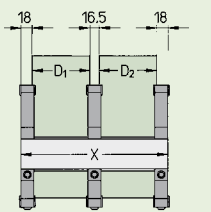

$$x = 52 + D1 + D2$$

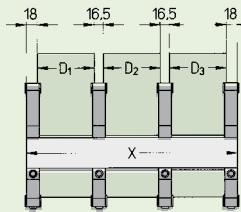

$$x = 69 + D1 + D2 + D3$$

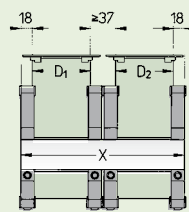

$$x \geq 73 + D1 + D2$$

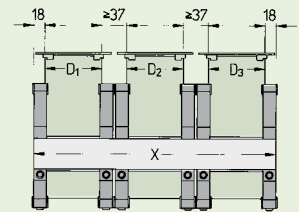

$$x \geq 110 + D1 + D2 + D3$$

Delivery program

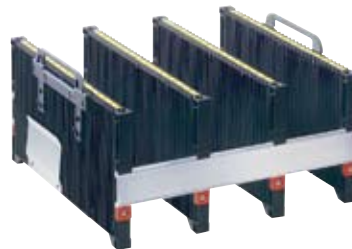







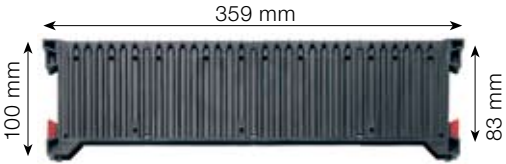

Part No.	Description
8910063	PCB Magazine Testset 100
e.g. for 100 mm wide PCBs	Contents: 4 Side Walls 100 2 Profiled Rails 369 mm long 1 Document Clamp
Weight:	1.4 kg

Part No.	Description
8910064	PCB Magazine Testset 180
e.g. for 100 mm wide PCBs.	Contents: 4 Side Walls 180 2 Profiled Rails 369 mm long 1 Document Clamp 1 Set Carrying Handles
Weight:	2.5 kg

Part No.	Description
8910065	PCB Magazine Testset 300
e.g. for 233.4 mm wide PCBs.	Contents: 2 Side Walls 300 4 Profiled Rails 269 mm long 1 Document Clamp 1 Set Carrying Handles
Weight:	2 kg

Delivery program

	Part No.	Description	Weight	PU 1	PU 2
	8910050	Rack Wall 100	0.28 kg	1 piece	30 pieces
	8910102	Rack Wall 100 reinforced	0.40 kg	1 piece	30 pieces
	8913913	Rack Wall 100 with drilling for Slot Lock	0.28 kg	1 piece	30 pieces
	8910060	Rack Wall 180*	0.53 kg	1 piece	30 pieces
	8910104	Rack Wall 180* reinforced	0.65 kg	1 piece	30 pieces
		*incl. Drilling for Slot Lock			
	8912049	Rack Wall 300	0.7 kg	1 piece	18 pieces
	8913914	Rack Wall 300 with drilling for Slot Lock	0.7 kg	1 piece	18 pieces
 <p data-bbox="252 1480 727 1536">The profiled rails are supplied according to your requirements, xxxx is the length in mm.</p>		Length in mm			
	8910136	Profiled Rail 0136	0.06 kg	2 pieces	-
	8910252	Profiled Rail 0252	0.11 kg	2 pieces	-
	8910547	Profiled Rail 0547	0.24 kg	2 pieces	-
	8911000	Profiled Rail 1000	0.45 kg	2 pieces	-
	8912000	Profiled Rail 2000	0.90 kg	2 pieces	-
	891xxxx	Profiled Rail xxxx		2 pieces	-
	8910009	Document Clamp		1 set	25 sets
	8912004	Support Bar 100		1 set	10 sets
	8912005	Support Bar 180		1 set	10 sets
	8912006	Support Bar 300		1 set	10 sets
	8912007	Carrying Handle 100		1 set	25 sets
	8910097	Carrying Handle 180/300		1 set	25 sets
 <p data-bbox="320 2040 619 2063">Slot Lock 1 Slot Lock 2</p> <p data-bbox="376 2085 563 2107">pictures increased</p>	8913916	Slot Lock 1		100 sets	-
	8913917	Slot Lock 2		100 sets	-

for automated assembly lines



1 Locking knob for stacking purposes

2 Transport safety

3 Consecutive numbering on the side panels for easy feeding

4 The precision spindles ensure the parallelism of the sidewalls during adjustment

5 The gear belt allows for quick adjustments in seconds

Automation Requires Precision

Precision, stability and flexible handling are important features for the use of the PCB Magazines in automated assembly lines.

The stable and robust frame construction guarantees a long lasting use of the cab magazine in your production. The sidewalls are manufactured from conductive material.

Metal magazine

For high mechanical or temperature use we offer the magazine with metal sidewalls.





Series 600 - Width adjustment by screw clamp

The series 600 is cost effective alternative with a simple width adjustment. By backing off the four screw clamps the movable side panel can be pushed to the necessary PCB width.



Series 700 - Width adjustment by gear belt

Handling different PCB sizes the magazines have to be adjusted to the PCB width quite often. The PCB Magazines of the series 700 are adjusted to the necessary PCB width within seconds.



Series 800 - Full automatic width adjustment

Increase process safety and optimize your production process by the automatic width adjustment of the cab magazines in unloaders.

on request



Stackable

The magazines can be stacked and secured space saving by four support guides on the top of the plate.



Reversible

Through to the vertical symmetry all magazines can be placed upside down to work on double sided PCBs. The stacking locator knobs must be replaced.

Magazine locked

Magazine unlocked

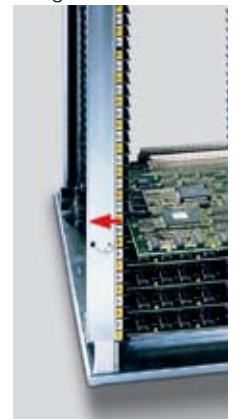

Transport safety

To secure the PCBs while transporting the magazine, a safety bar is mounted on the front and back side of the side panel.

Technical data

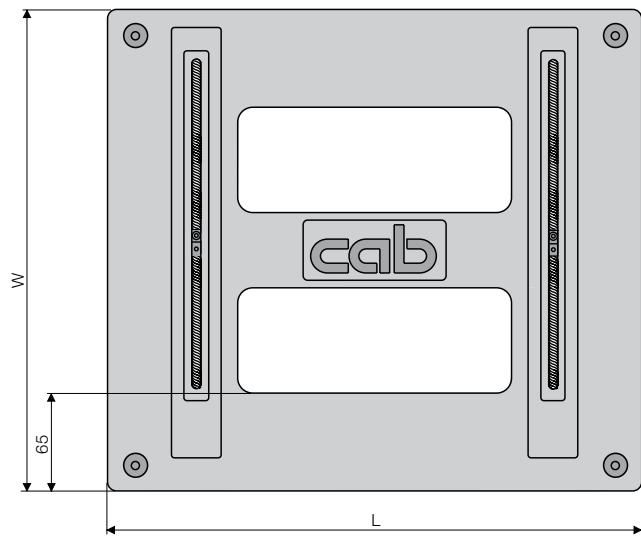
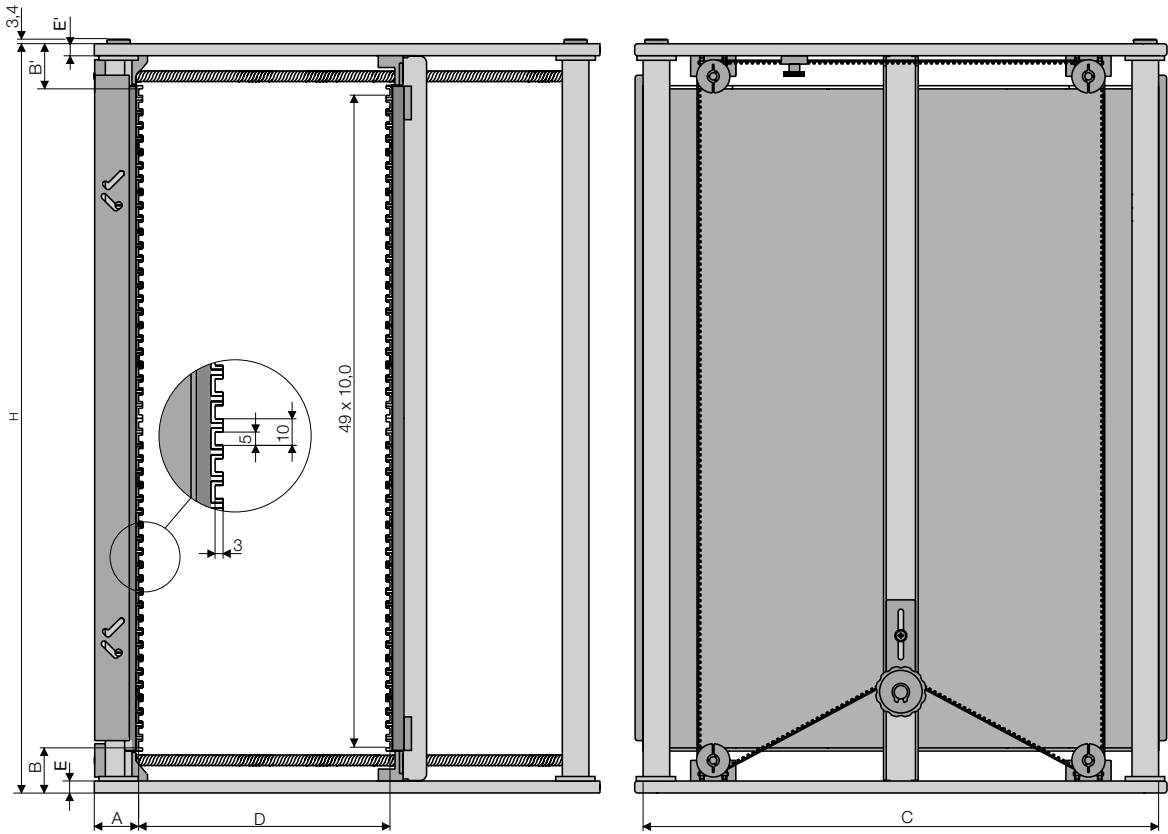

Series	Material side wall	Surface resistance
600.1 700.1	Polystyrene	as per DIN EN
600.2 700.2	Polycarbonat	61340-5-1
600.3 700.3	Metall*	$< 10^9$



*Measured from rack wall to frame

Technical data

Type	Article No.	Temperature		Weight kg	PCB						Cover/basem.		A mm	B mm	B' mm	E mm	E' mm	Pitch mm	Insertions	Screws	Gear belt	Stackable	Reverse operation
		C° Insertions	C° Ambient		External measurements			Width D		Length C max. mm	Die cast aluminium	Steel sheet											
					L mm	W mm	H mm	min. mm	max. mm														
601.1	8917601	60	50	5,6	355	320	563	40	250	342	■	-	34	34	34	9	9	10	50	■	-	■	■
601.2	8916601	130	100	5,9																			
601.3	8915601	200	200	6,9																			
602.1	8917602	60	50	5,8	400	320	563	40	250	387	■	-	34	34	34	9	9	10	50	■	-	■	■
602.2	8916602	130	100	6,1																			
602.3	8915602	200	200	7,2																			
603.1	8917603	60	50	6,2	400	380	563	40	310	387	■	-	34	34	34	9	9	10	50	■	-	■	■
603.2	8916603	130	100	6,5																			
603.3	8915603	200	200	7,6																			
701.1	8917701	60	50	5,6	355	320	563	40	250	342	■	-	34	34	34	9	9	10	50	-	■	■	■
701.2	8916701	130	80	5,9																			
701.3	8915701	200	100	6,9																			
702.1	8917702	60	50	5,8	400	320	563	40	250	387	■	-	34	34	34	9	9	10	50	-	■	■	■
702.2	8916702	130	80	6,1																			
702.3	8915702	200	100	7,2																			
703.1	8917703	60	50	6,2	400	380	563	40	310	387	■	-	34	34	34	9	9	10	50	-	■	■	■
703.2	8916703	130	80	6,5																			
703.3	8915703	200	100	7,6																			
704.1	8917704	60	50	7,8	460	400	563	10	330	447	-	■	34	34	34	9	9	10	50	-	■	■	■
704.2	8916704	130	80	8,0																			
704.3	8915704	200	100	9,5																			
705.2	8916705	130	80	8,7	535	380	570	10	310	522	-	■	34	41	34	16	9	10	50	-	■	■	-
705.3	8915705	200	100	10,1																			
715.2	8916715	130	80	8,7	535	380	563	10	310	522	-	■	34	34	34	9	9	10	50	-	■	■	■
715.3	8915715	200	100	10,1																			
706.2	8916706	130	80	9,5	535	460	570	10	390	522	-	■	34	41	34	16	9	10	50	-	■	■	-
706.3	8915706	200	100	10,9																			
716.2	8916716	130	80	9,5	535	460	563	10	390	522	-	■	34	34	34	9	9	10	50	-	■	■	■
716.3	8915716	200	100	10,9																			
707.2	8916707	130	80	9,7	535	530	570	10	460	522	-	■	34	34	41	9	16	10	50	-	■	■	-
707.3	8915707	200	100	11,1																			
717.2	8916717	130	80	9,7	535	530	563	10	460	522	-	■	34	34	34	9	9	10	50	-	■	■	■
717.3	8915717	200	100	11,1																			
708.2	8916708	130	80	9,6	535	470	570	10	400	522	-	■	34	41	34	16	9	10	50	-	■	■	-
708.3	8915708	200	100	11,0																			
718.2	8916718	130	80	9,6	535	470	563	10	400	522	-	■	34	34	34	9	9	10	50	-	■	■	■
718.3	8915718	200	100	11,0																			

- xxx.1 Rack wall Polystyrene
- xxx.2 Rack wall Polycarbonat
- xxx.3 Rack wall Metal

The PCB-magazines are delivered half-assembled. Assembled magazines can be ordered with additional article numbers.

	DL31001	Assembled with staple neps
	DL 31002	Assembled for reserve operation



The current specifications are according to our technical knowledge. They are subject to change.

Germany

cab Produkttechnik
GmbH & Co KG
Postfach 1904
D-76007 Karlsruhe
Wilhelm-Schickard-Str. 14
D-76131 Karlsruhe
Telefon +49 721 6626-0
Telefax +49 721 6626-249
www.cabgmbh.com
info@cabgmbh.com

France

cab technologies s.a.r.l.
B.P. 50020
Z.A. Nord du Val de Moder
F-67350 Niedermodern
Téléphone +33 388 722 501
info@cab-technologies.fr

España

cab España S.L.
Josep Pla 9, 6º, 2ª
E-08304 Mataró (Barcelona)
Teléfono +34 937 414 605
info@cabsl.com

USA

cab Technology Inc.
90 Progress Avenue Unit #2
Tyngsboro MA, 01879
Phone +1 978 649 0293
www.cabtechn.com
info@cabtechn.com

South Africa

cab Technology (Pty.) Ltd.
14, Republic Road
2125 Randburg
Phone +27 11-886-3580
info@cabtech.co.za

Asia 亞洲分公司

希愛比科技股份有限公司
cab Technology Co, Ltd.
台灣台北縣板橋市
民生路一段33號十九樓之一
19F-1, No. 33, Sec. 1,
Min Sheng Road
Panchiao 220,
Taipei, Taiwan, R.O.C.
電話 Phone +886 2 2950 9185
網址 www.cabasia.net
詢問 cabasia@cabgmbh.com